



RAPCO BOOT SAVER™

Space age material for the repair of
WING DE-ICE AND PROPELLER BOOTS
*NO MORE PATCHES OR
 PREMATURE BOOT REPLACEMENTS*

X-1567
 Black



Wing Walk

MIL-W-5044
 Type 2

- Major Dollars Savings in Boot Replacement Costs
- Get Rid of Unsightly Patches
- Repairs the Smallest Pinhole to Large Damaged Areas
- Keeps Your Boots Working
- Increases Your Aircraft Resale Value

Part No. **200-WB** for **WING BOOTS**

Part No. **201-PB** for **PROP BOOTS**

NOSE COAT

A rubberized coating for use over fiberglass areas to prevent weather and other related erosion.

- Dries Fast – 10-15 minutes
- No Mixing Required – Just apply as is, from the can
- Sponge Pad Applicator FREE with Each Can
- Won't Affect Radar Operation
- Lowest Cost Erosion Protection Available
- One Quart Covers Approximately 40-50 Sq. Ft.
- Available in Black Only

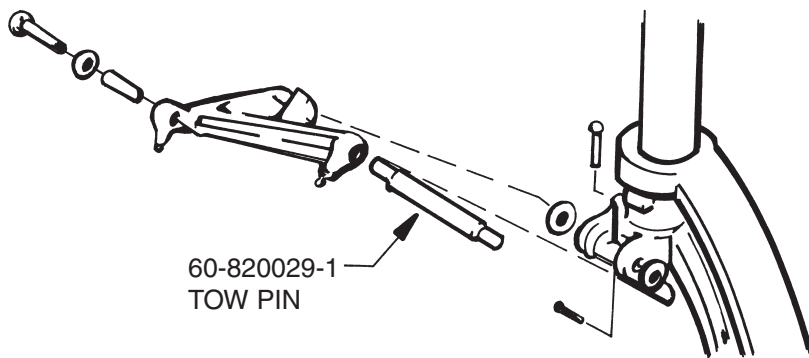

TOW PIN

FAA/PMA APPROVED
 REPLACEMENT
 for Beechcraft
 Part No. **60-820029-1** Tow Pin

© 2005 Trimcraft Aviation